



SANDVIK CV200 RANGE VERTICAL SHAFT IMPACT CRUSHERS (VSI)

TECHNICAL SPECIFICATION

CV200 RANGE VSI CRUSHER - OPERATIONAL FLEXIBILITY

Sandvik Stationary VSI impact crushers are designed for higher capacity, reduced power consumption, reduced maintenance costs and intervals.

In the aggregate, mining and quarrying sectors, Sandvik VSI impact crushers are used for production of high-quality manufactured sand and premium shaped aggregates. Other application areas include rolled compressed concrete (RCC) for dam construction, recycling industries crushing a range of materials (concrete, glass, slag, etc.) and industrial minerals plants, crushing extremely abrasive high-value materials.

The autogenous "rock on rock" crushing technique results in several major advantages, such as: product gradation remains constant, contamination rates are extremely low and an unbeatable product shape.

The rotor, being the heart of the crusher, is designed for high capacity with a low power consumption.

Customer feedback has played a vital role in the designs of these machines, ensuring the most productive, efficient, and suitable products available in the market today.

ADVANTAGES

Premium shaped aggregates

Easy and safe maintenance

Low operational cost per tonne

Reduced power consumption

APPLICATION AREAS

Industrial minerals

Manufactured sand production

Recycling

Mining & aggregate production



AUTOGENOUS "ROCK ON ROCK" CRUSHING TECHNIQUE

The crusher operates by accelerating the material to be crushed via a high energy (patented) rotor, into a crushing chamber lined with the same material. This gives the rock on rock (autogenous) crushing action.

Where a product size is required below that of the feed size, it is usual to operate the crusher in closed circuit, with a screen of appropriate size and adequate capacity. However, the crusher can be operated in open circuit. In both cases a screen is required for final sizing. Product gradation is further controlled by the rotational speed of the rotor and /or the quantity (percentage) of Bi-Flow[®] used.

The material going through the Bi-Flow gates falls into the crushing chamber through channels and is then hit from opposite direction by the material coming from the rotor.

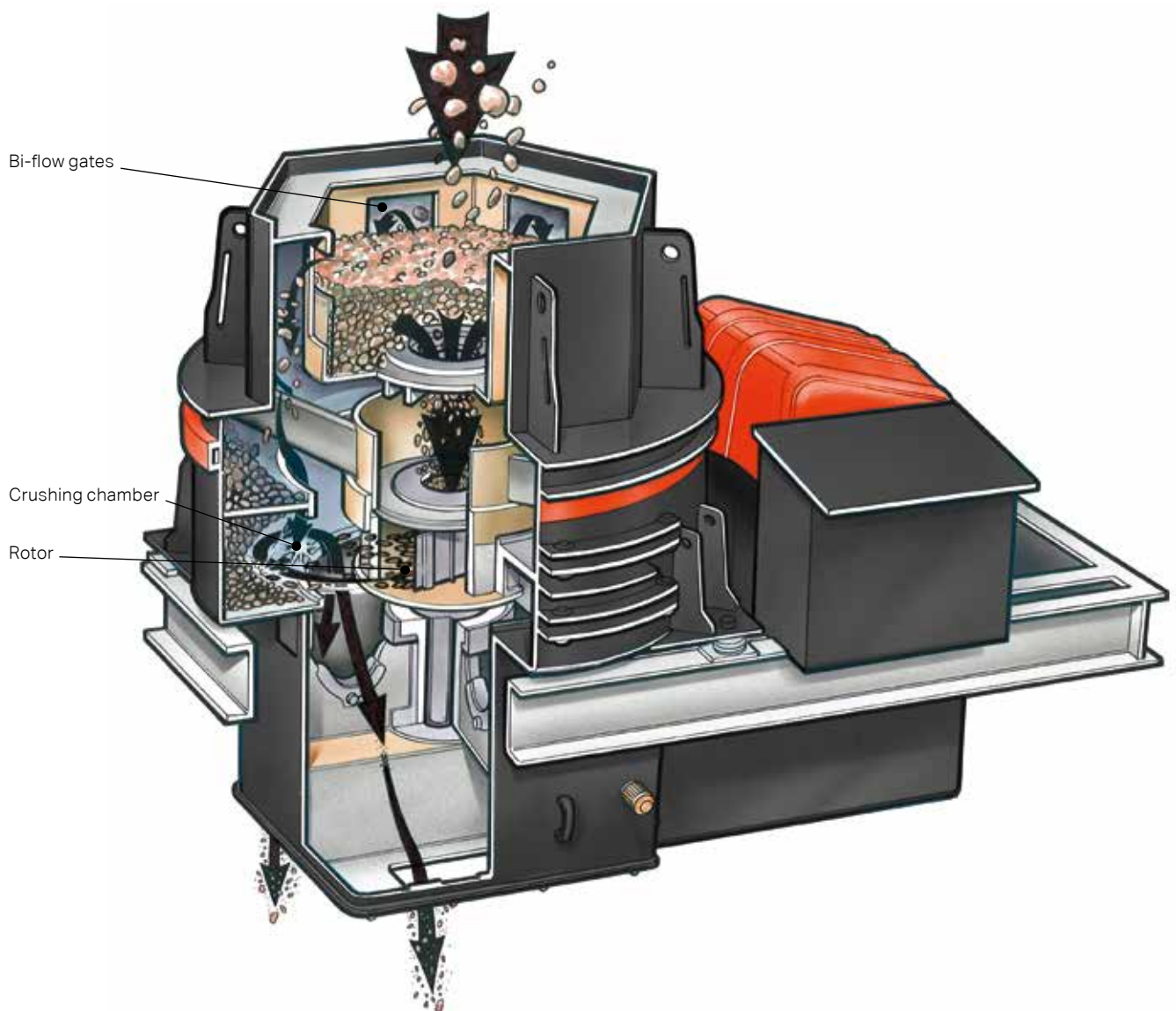

INSTALLED POWER AND CRUSHER CAPACITY WITH STANDARD SPEED

The crushers should **not operate below the required minimum capacities** for a given crusher range. Operation below the minimum can result in:

- Reduced crushing action and hence reduced predicted production.
- Reduced rock lining within the crusher, leading to possible crushing chamber damage.
- An increase of larger gradation sized recirculating load, which can again in turn lead to crushing chamber and rotor wear part failure.

Optimum operation of the crusher (lowest possible cost per ton), is always achieved when operating the crusher at the relevant maximum tonnage throughput. Therefore, generally, it is advisable to select a crusher which will operate at the given maximum tonnage throughput for a given range.

Any situation where the crusher is operated with intermittent reduced or no feed, should be avoided, as this again reduces the efficiency of the crusher and may cause damage to the crusher as previously described.

As a general rule the following should be remembered:

- Increased tip speed gives a finer product gradation.
- Increased tip speed reduces rotor throughput.
- Increased tip speed increases the power consumption per tonne of rotor throughput.

The Sandvik VSI crushers are delivered with a fixed rotor speed depending of the crusher model. It is possible to order different pulleys and taper locks that will change the rotor speed.

However, the fixed rotor speed is chosen with many years' experience in mind and the benefits of changing to other rotor speed can only be seen in few cases.

Increasing the speed of the rotor from nominal to maximum, will only increase the finer product discharge from the crusher by about 3%. But this also increase wear parts consumption and decreases the throughput of desired product.

To change product gradation, we recommend using the patented Bi-Flow system together with the Rotor Throttle that controls the feed to the rotor.

Below is a comparison between nominal speed and maximum speed on a CV217.

OPTIONAL HIGHER SPEED

- CV217 operating at 62 M/sec.
- Total max. throughput at 185 kw = 141 tph
- Typical net production of -5mm product (from 5 – 35mm feed)

Result: 53 tph -5mm product

STANDARD SPEED

- CV217 operating at standard 52 M/sec.
- Total max. throughput at 185 kW = 252 tph.
- Typical net production of -5mm product (from 5 – 35mm feed)

Result: 90 tph -5mm product

CRUSHER DRIVE SYSTEM

MOTOR CHARACTERISTICS

MODEL	CV215	CV216	CV217	CV218	CV228	CV229
Manufacturer	ABB					
Type	Squirrel cage Induction Motor IE3 (IS 12615:2011)					
Rated power	55 kW	110 kW	185 kW	220 kW	2 x 185 kW	2 x 250 kW
Frequency	50/60 Hz					
Poles	4	4	4	4	4	4
Insulation class	F	F	F	F	F	F
Protection class	IP55	IP55	IP55	IP55	IP55	IP55
Max allowed power	55 kW	110 kW	185kW	220kW	2 x 185 kW	2 x 250 kW

ROTOR SPEED ALTERNATIVES (ONLY MOTOR PULLEY AND TAPER LOCKS NEED TO BE CHANGED TO ALTERNATE THE ROTOR SPEED)

MODEL	CV215	CV216	CV217	CV218	CV228	CV229
m/s (50Hz)	49, 59, 62, 66	43, 46, 49, 55, 59, 62	43, 46, 48, 55, 58	53, 63	53, 63	53, 63
m/s (60Hz)	50, 59, 62, 66	43, 46, 49, 55, 59, 62	46, 49, 55, 59	53, 59	53, 59	53, 59
Max allowed	69	62	62	63	63	63
Standard speed (best in most applications)	52	52	51 (50Hz) 52 (60 Hz)	55	55	55

ADVANCED ROTOR AND WEAR PARTS

The highly advanced and efficient rotor is a 3-port model that has been developed with many years of experience.

The diameter and the height of the rotor gives efficient and low power consumption crushing.

The Sandvik VSI consist of few wear parts which reduces downtime and stockholding. The rotor and wear parts are constantly being developed at Sandvik to comply with our customers applications and needs.

There are different types of wear parts to use depending on material to be crushed. For demanding and tearing applications we have premium wear parts that extend lifetime many times compared to standard.

Contact your local Sandvik representative for more information on which wear parts that suits your application best.



HP ROTOR

ROTOR TYPE

MODEL	CV215	CV216	CV217	CV218	CV228	CV229
Rotor	73EP	73LP	73LP	85HP	85HP	85HP

BI-FLOW

The Bi-Flow® system is a very versatile tool. Maximum crushing efficiency, when using Bi-Flow® in a given crusher range, can be realized when the following parameters have been selected:

- Maximum motor size for the relevant crusher size.
- Tip speed selected at 0.9-1Kw / Tonne rotor throughput.
- Crusher operated at maximum motor amps. with rotor only feed.
- Addition of up to a further 20% extra material into Bi-Flow®, resulting in no change to the "rotor only" product curve.

Example:

CV216 crusher fitted with a 50Hz 110Kw motor.

Tip Speed 52 M/Sec.

Rotor throughput 120 tph

Bi-Flow® material = 23 tph. i.e. Rotor throughput x 20%.

Total crusher throughput 143 tph.

Varying the ratios of rotor to Bi-Flow® feed material can be extremely beneficial when attempting to "tailor" a product for the customer. However, this is best done on site during the commissioning stage.

PRODUCT CURVES

Size distribution of the product is affected by the following factors:

- The work index of the material (Wi).
- The speed of the rotor (Tip Speed in Metres per Second).
- The size of the feed material.
- The ratio of Bi-Flow® material to rotor throughput.

Other influencing factors to consider for general crushing duties are:

- High tip speeds generally result in higher wear rates within the rotor and crusher.
- Low tip speeds generally result in higher recirculating loads, which in turn can lead to the requirement of increased screening area and conveyor size.

Theoretical product curves with different WI and same feed.

Periferal rotor speed 51 m/s.

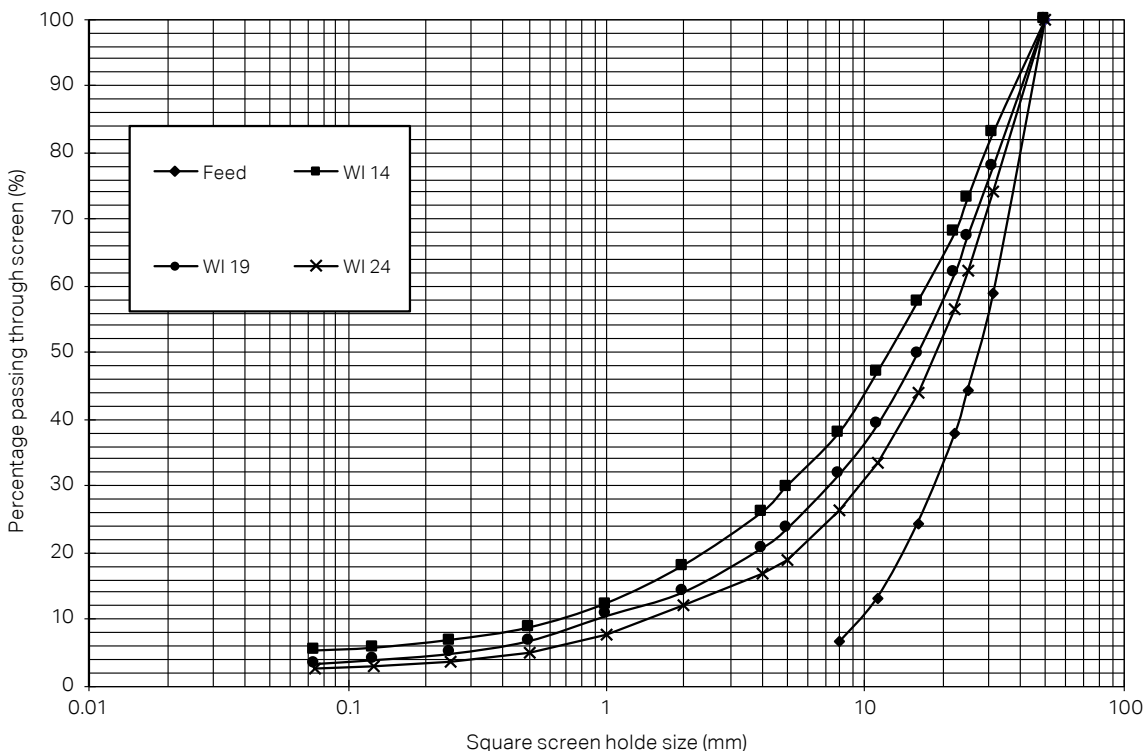

MANUAL CRUSHER SELECTION

1. Determine the maximum feed size.
2. The minimum feed size to the crusher, must always be less than 25mm (1"), in either open or closed circuit.
3. Determine the total tonnage throughput of the crusher:
 - a) Open Circuit – Refer to capacity tables on previous pages, detailing maximum and minimum recommended tonnages.
 - b) Closed Circuit – Determine the maximum product size required and select a suitable lab screen aperture (cut size).
 - b₁) Determine the Work Index (Wi) of the material to be crushed and choose the nearest applicable product curve from the tables on previous pages.
 - b₂) Calculate the amount of re-circulating load to the crusher, by referring to the applicable table.

Example

- a) Wi=14 curve selected in above table.
- b) 5 mm sand required.
- c) Table A1 indicates a 30% breakage ratio at 5mm.
- d) Product required at the rate of 100 TPH.
- e) Total throughput of the crusher = Product TPH (100) x 100 / 30 (% breakage) = 333 MTPH.
- f) Select the relevant crusher from the capacity tables = CV228.

TONNAGE THROUGHPUTS

It is vitally important that the correct size of crusher is selected for the required application. Be aware that when operating the crusher in closed circuit, the total crusher load needs to be used in calculations (raw feed plus return feed).

In capacity tables the minimum and maximum recommended throughputs for each crusher range with normal peripheral speed are detailed. Other speed of rotor is available. The minimum and maximum recommended throughput with other speed is available.

The throughput figures will vary with bulk densities of the material being crushed.

STANDARD SCOPE OF CRUSHER

FEED HOPPER fitted with Bi-flow adjustment system

ROTOR with all necessary standard wear parts fitted.

One complete spare rotor with standard wear parts and tip plates. Non standard wear parts are available for abrasive material.

FRAME ARRANGEMENT

Crusher support frame with anti-vibration dampers and transportation legs.

Motor Mounting Bracket with hydraulic (belt tensioning) adjustment.

SETTING ADJUSTMENT

Hydraulic rotor throttle adjustment system

Feed hopper control plates to control the feed rate to the rotor

BEARING LUBRICATION SYSTEM

Grease distribution system including semi-automatic lubrication unit, sealed and sufficient for 2,000 hrs operation. (options for tropical climate or hot material available)

DRIVE

Drive kit consisting of crusher and motor pulley(s) for standard speed, V-belts (cogged raw edge SPC) and bushings.

Electrical 4 pole multi-voltage motor including composite Motor Cover

Bearing Temperature Sensor fitted to drive end bearing house

INTERLOCK KIT

Safety Interlock Kit. Unique key access to each individual crusher(s)

MISCELLANEOUS

Toolbox

Rotor lifting kit

Pre-Start Alarm

Vibration sensor



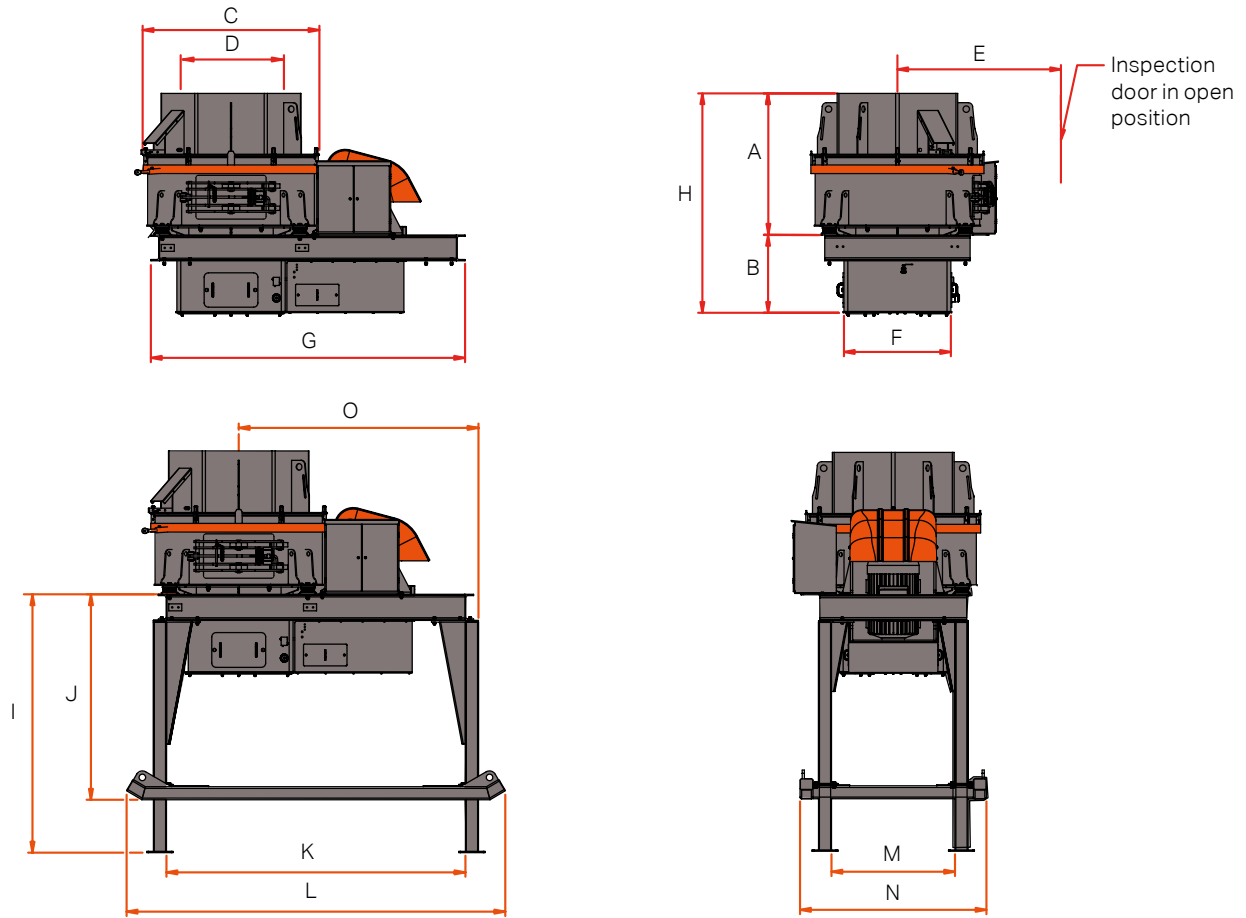

MODEL	CV215		CV216		CV217		CV218	
A	1,212	(47 3/4")	1,648	(64 7/8")	1,648	(64 7/8")	2,130	(83 7/8")
B	790	(31 1/8")	905	(35 5/8")	905	(35 5/8")	931	(36 5/8")
C	1,730	(68 1/8")	2,040	(80 3/8")	2,040	(80 3/8")	2,444	(96 1/4")
D across flats	902	(35 1/2")	1,016	(40)	1,016	(40)	1,216	(47 7/8")
E	1,840	(72 3/8")	1,912	(75 1/4")	1,912	(75 1/4")	2,090	(82 1/4")
F	1,070	(42 1/8")	1,250	(49 1/4")	1,250	(49 1/4")	1,420	(56)
G	3,166	(124 5/8")	3,626	(142 3/4")	3,626	(142 3/4")	3,750	(147 5/8")
H	2,002	(78 7/8")	2,553	(100 1/2")	2,553	(100 1/2")	3,061	(120 1/2")
I	2,231	(87 7/8")	2,970	(117)	2,970	(117)	3,076	(121 1/8")
J	2,362	(93)	2,362	(93)	2,362	(93)	2,480	(97 5/8")
K	2,978	(117 1/4")	3,438	(135 3/8")	3,438	(135 3/8")	3,562	(140 1/4")
L	4,355	(171 1/2")	4,352	(171 3/8")	4,352	(171 3/8")	4,355	(171 1/2")
M	1,170	(46)	1,430	(56 1/4")	1,430	(56 1/4")	1,480	(58 1/4")
N	2,158	(85)	2,158	(85)	2,158	(85)	2,228	(87 3/4")
O	2,427	(95 1/2")	2,757	(108 1/2")	2,757	(108 1/2")	2,806	(110 1/2")
Weight kg (lbs)	6,000	(13,228)	9,500	(20,944)	9,500	(20,944)	11,776	(25,963)
Maximum feed size mm (in)	40	(1 5/8")	50	(2")	50	(2")	55	(2 3/16")
Capacity range MTPH (short tons)	10-50	(11-55)	51-121	(56-146)	122-192	(134-211)	193-250	(212-275)
Rotor rpm range (60Hz speed)	1,568-2,101	(1,576-2,112)	1,381-1,982	(1,388-1,980)	1,388-1,973	(1,487-1,965)	1,401-1,677	(1,408-1,666)

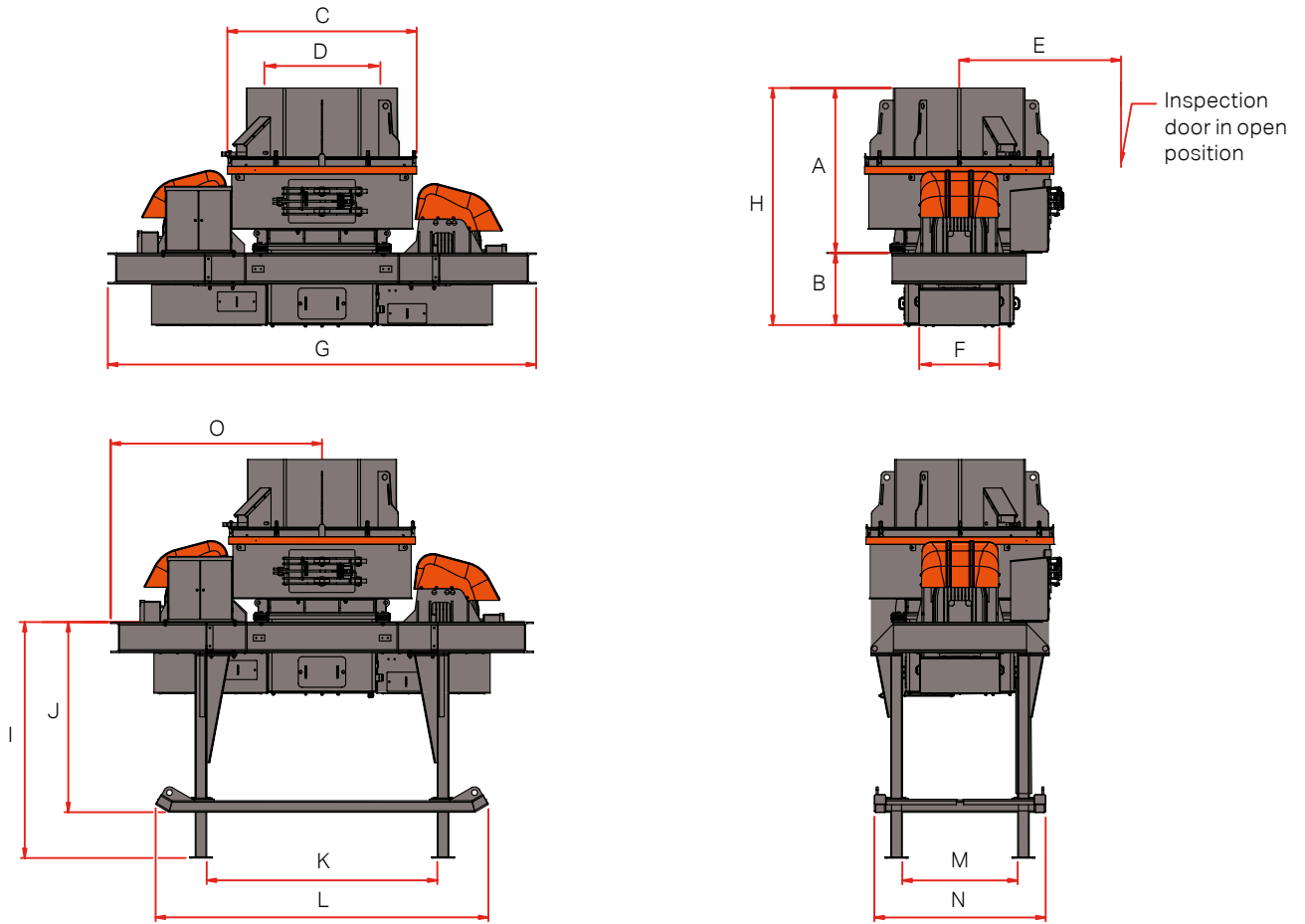

MODEL	CV228		CV229	
A	2,130	(83 7/8")	2,130	(83 7/8")
B	931	(36 5/8")	931	(36 5/8")
C	2,444	(96 1/4")	2,444	(96 1/4")
D across flats	1,216	(47 7/8")	1,216	(47 7/8")
E	2,090	(82 1/4")	2,090	(82 1/4")
F	1,420	(56)	1,420	(56)
G	5,500	(216 1/2")	5,500	(216 1/2")
H	3,061	(120 1/2")	3,061	(120 1/2")
I	3,090	(121 5/8")	3,090	(121 5/8")
J	2,480	(97 5/8")	2,480	(97 5/8")
K	3,018	(118 7/8")	3,018	(118 7/8")
L	4,355	(171 1/2")	4,355	(171 1/2")
M	1,500	(59)	1,500	(59)
N	2,228	(87 3/4")	2,228	(87 3/4")
O	2,750	(108 1/4")	2,750	(108 1/4")
Weight kg (lbs)	14,826	(32,686)	14,826	(32,686)
Maximum feed size mm (in)	55	(2 3/16")	55	(2 3/16")
Capacity range MTPH (short tons)	251-444	(276 – 489)	445-600	
Rotor rpm range (60Hz speed)	1,401-1,677	(1,408 – 1,666)	1,401-1,677	(1,408–1,666)

OPTIONS

SUPPORT OPTIONS

- Access stairs and platform that enable safe and easy maintenance and access to the crusher.
- Skid Frame that makes the crusher semi-mobile.
- Long or short support legs. Short support legs are used for above skid frame. The long legs are used when crusher is mounted on concrete.

MOIST MATERIAL OPTIONS

When the material to be feed into the crusher contains between 3 and 8% moist, the material intends to stick in the crusher. This might cause feeding problems, but the following options will reduce the possibility for having problem with moist material. One single option can be chosen as well as all four. It depends where in the crusher the problem occurs.

- Bi-Flow Acceleration slides
- Base Water Spray kit
- Transmission Non-Stick liners
- Crushing chamber Water Spray Kit (not available for CV215)

DISCHARGE SHUTES

The chute ensures that material exits the base of the crusher freely without blocking. Can be fitted either left or right handed. Not available for CV215.

DRIVE PULLEYS

A range of drive pulley that controls the rotor speed are available for the crushers. It is only required to change the drive pulley for changing rotor speed.

DUST ENCAPSULATION

The dust emitted from the crusher during operation is minimal but if operating the crusher with low or no feed increases the amount of dust emitted from the crusher. This Dust encapsulation keeps the dust inside the crusher.

ELECTRICAL CONTROL PANEL

This control panel has been specifically designed for use with the VSI crushers. The control panel ensures correct starting and operation. the following features are included:

- Hours run meter
- Molded case circuit breakers
- Anti Condensation Heater (A.C.H)
- Terminals for remote control
- Pre-Start alarm that sounds in 15 seconds before the crusher starts.

AUTOMATIC GREASING UNIT

The Automatic greasing unit will keep the crusher properly greased during operation. Together with the included Rapid fill pump it keeps the grease clean and possible air locks to a minimum.

HIGH TEMPERATURE BEARING CARTRIDGE

To be used if the crusher is intended to be operating in hot climate or to be feed with hot material, such as material coming from a furnace or drier.

Viton Seals have replaced the standard Nitrile type and the cartridge contains synthetic high temperature grease instead of standard grease.

ROTOR BALANCE MACHINE

The Rotor Balance Machine is used when balancing the rotor after routine periodic repair.

ELECTRICALLY OPERATED HYDRAULIC ROTOR THROTTLE

This unit adjust the rotor throttle easily via a control box instead of manual adjusting it.

WEAR PARTS

Sandvik develop new and alternative wear parts continuously to be used in different applications with different level of abrasive material. This is to extend the life time and reduce downtime. Consult Sandvik for more information on how to optimize your VSI crusher.

RETROFIT KITS

It is possible to optimize old VSI crushers of various brands and manufacturers.

The rotor can be changed to an advanced SANDVIK VSI rotor or the complete top half can be replaced.

Some of the benefits are:

- Reduced power consumption
- Increased throughput
- Easier maintenance
- Safer maintenance including the Safety interlock system
- Fewer parts on the rotor
- Ability to change feed tube through the inspection door without removing the crusher roof and hopper.
- The benefits of the Sandvik Bi-Flow system
- Sandvik premium wear parts can be used

EXAMPLE OF APPLICATIONS WHERE SANDVIK VSI CRUSHERS ARE USED

- For differential crushing to liberate ores (gold heap leaching etc.)
 - To remove contaminants (clay, lignite, sandstone, etc.).
 - Production of De-Gasser for steel industries.
 - Production of fertiliser from steel furnace slag.
 - To manufacture sand – a growing market area due to the increased worldwide environmental restrictions for digging natural sand.
 - In applications where superior product shape is required, e.g. concrete aggregate / sand, road surfacing.
 - In Mining applications, to reduce the feed size to the ball mills, enabling huge savings to be realised
- In Mining applications, to reduce the feed size to the ball mills, enabling huge savings to be realised in both mill charge and tonnage throughput of the mills.
- Glass recycling

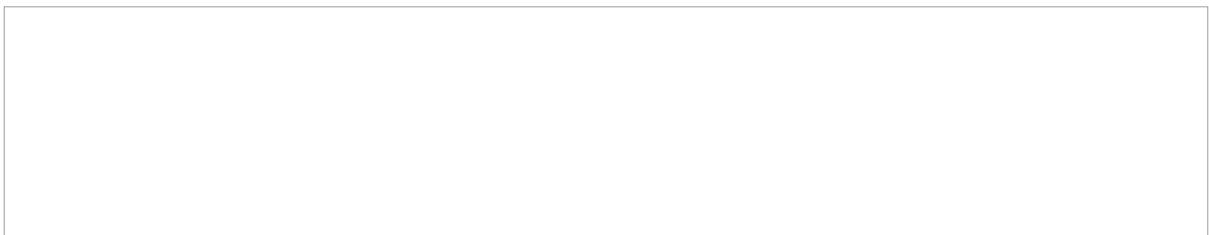

Sandvik Mining and Rock Technology reserves the right to make changes to the information on this data sheet without prior notification to users. Please contact a Sandvik representative for clarification on specifications and options.